

570-DCLN
95°

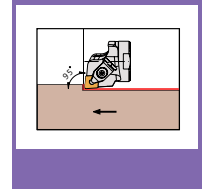
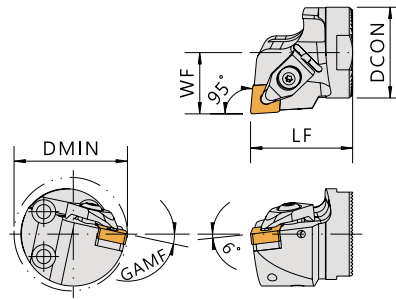
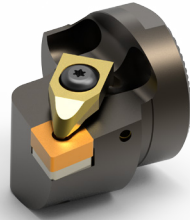

with coolant 有水孔

Order No.	Insert	Dimensions(mm)					Parts						Wrench	
		柄徑 DCON	工作寬度 WF	長度 LF	最小加工徑 DMIN	徑向前角 GAMF								
570-DCLNR-40-12	CNMG1204	40	27	38	50	12°	SMC-422	CSF4010	CP-D4	SP0816	CSB0620T	TL20	LW025	

*Dia:40mm(柄徑)→Connection Screw(連接螺絲):CSH0620 / Center Pin(中心梢):WSD6-570 / Wrench(板手):LW050

570-DTFN
91°

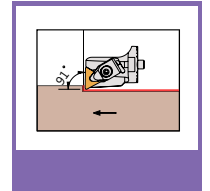
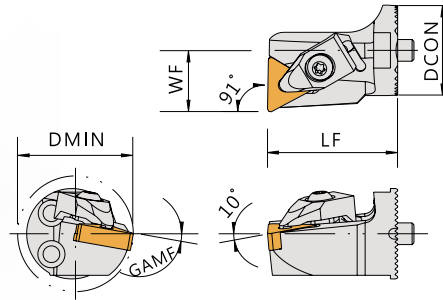
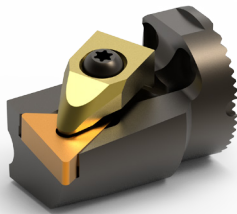

with coolant 有水孔

Order No.	Insert	Dimensions(mm)					Parts						Wrench	
		柄徑 DCON	工作寬度 WF	長度 LF	最小加工徑 DMIN	徑向前角 GAMF								
570-DTFNR-25-16	TNMG1604	25	17	36	32	10°	-	-	CP-D2	SP0612	CSB0415T	TL15		
570-DTFNR-32-16	TNMG1604	32	22	36	40	10°	SMT-323	CSA40075	CP-D2	SP0612	CSB0415T	TL15		

*Dia:25mm(柄徑)→Connection Screw(連接螺絲):CSH0414 / Center Pin(中心梢):WSD6-570 / Wrench(板手):TW040

*Dia:32mm(柄徑)→Connection Screw(連接螺絲):CSH0516 / Center Pin(中心梢):WSD6-570 / Wrench(板手):LW040

570-DTUN
93°

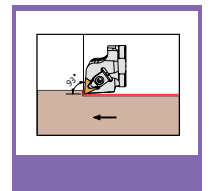
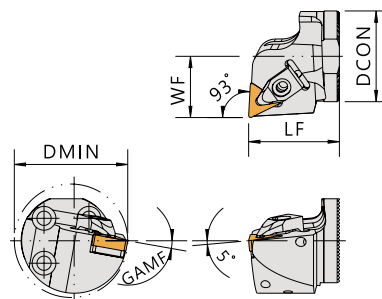
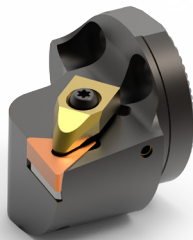

with coolant 有水孔

Order No.	Insert	Dimensions(mm)					Parts						Wrench	
		柄徑 DCON	工作寬度 WF	長度 LF	最小加工徑 DMIN	徑向前角 GAMF								
570-DTUNR-40-16	TNMG1604	40	27	38	50	10°	SMT-323	CSA40075	CP-D2	SP0612	CSB0415T	TL15		

*Dia:40mm(柄徑)→Connection Screw(連接螺絲):CSH0620 / Center Pin(中心梢):WSD6-570 / Wrench(板手):LW050